

CRYOGENIC 2-PCS FLOATING BALL VALVE

Installation, Operation and Maintenance Manual

Series included: C84R2, C84F2, C85R2, C85F2, C87R2, C87F2

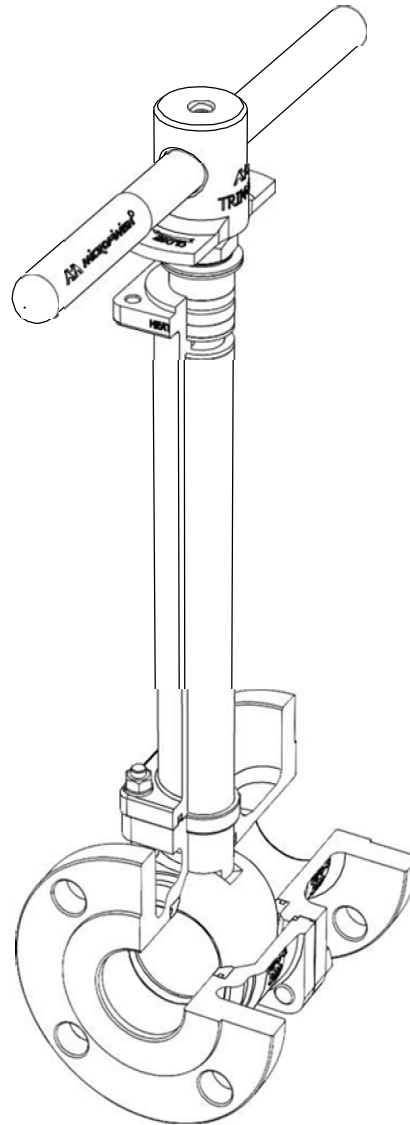

MICROFINISH VALVES

Quality you can trust.



Warnings & Safety Instructions

For your safety and protection, it is important that the following precautions be taken prior to working on valves.

- It is the prime responsibility of the end user to determine the appropriate compatible material of construction and the product ratings for the intended service.
- User shall ensure that the service parameters do not exceed the pressure – temperature limit (as specified on the nameplate).
- The valve should be used in a well-designed, adequately supported piping system such that it will not be subjected to undue forces or hydraulic shocks during service.
- Valve surface temperature may become extremely cold due to operating conditions. Prevent any type of direct contact with the valve that may harm or injury.
- The valves are not designed to operate during or after earthquakes or under fatigue conditions. It is the responsibility of the user to determine fatigue conditions and the appropriate measure taken for a safe use.
- Isolate the valve that exhibits any sign of leakage, and follow the instruction for safe maintenance.
- Read the entire IOM carefully and make sure everything is clear, if any doubts consult Microfinish engineering team.

Note: The drawings and images in this manual are for reference only.

1. Introduction

Microfinish cryogenic ball valves are designed and manufactured for long lasting, trouble free, service.

This Installation, Operating & Maintenance manual covers the instructions required for safe use of Microfinish cryogenic ball valve. Check the valve nameplate for identification of materials.

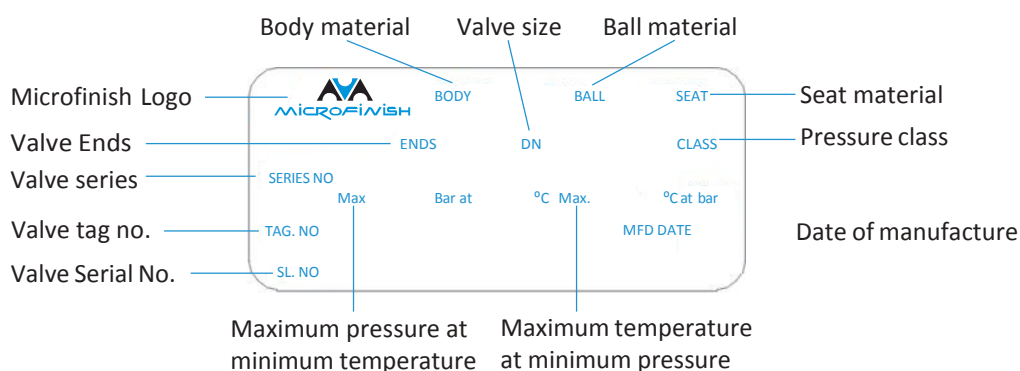

Storage

Prior to storage, inspect the valve for shipping damage. The valves are packed individually in a hermetically sealed plastic bag filled with dry nitrogen. It is recommended to keep the valve in its original bag and in a clean and protective environment until ready for use. Keep all protective packaging, flange covers and end caps attached to the valves during storage.

Long term storage

Valves intended for long-term storage (over 6 months), shall be kept as shipped, protected against humidity, moisture, dust, dirt, sand, mud, salt spray, and sea water. Manual ball valves will remain in the open position during the period of storage. Actuated valves (fail to close position) remain in closed position; (fail to open position) remain in open during this time.

Prior to Installation

Operate the valve at least two cycles prior to installation. Verify smooth operation, if valve stored exceeds 6 months in a long term storage, it is advisable to check and re-tighten the body fasteners as per the torque table 2 and the pattern defined in figure 4.

Flush the pipeline, and verify it is cleared of impurities such as sand, grit, welding splatters, or any particles that might damage the ball surface or valve internals.

2. Installation

2.1. General

2.1.1. Microfinish cryogenic ball valves are unidirectional; valve installation shall be in the direction indicated by the **arrow** mark attached to the body and bonnet (Refer Figure1). The arrow indicates the High pressure (HP) side, at its tail, and the low pressure (LP) side, at the arrow head. The arrow direction does not always indicate the normal direction of cryogen flow; on the contrary, in most applications the valve should be installed with the arrow pointing in the opposite to the normal direction of cryogen flow. To clarify this issue, the high pressure side should be specified when the flow stops and the valve is in its closed position; **Although it may seem trivial, Microfinish has found this to be a very common error in industry which causes double the work, a waste of raw materials, and even a safety concern.**

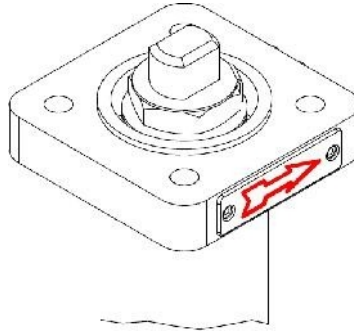

Figure 1. Arrow plate – Doesn't always indicates the direction of the flow

2.1.2. The function of the bonnet of a cryogenic valve is to allow proper heat transfer, and a steep temperature gradient along the bonnet's length between cryogenic temperatures as low as -196°C / -320°F and a temperature of around -10°C / 14°F at the cryogenic ISO top pad. This feature allows the soft parts of the valve stem seal to remain ductile. According to BS 6364 standard a 10 inch (250 mm) cryogenic bonnet shall be installed in the vertical position or inclined up to 45° from the vertical axis as shown in figure 2. For confined spaces and systems characterized by high vibration, Microfinish offers a 6 inch (150 mm) bonnet for sizes up to DN50. A cryogenic valve with 6 inch (150 mm) bonnet not compliant with BS 6364. A cryogenic valve with 6 inch bonnet shall be installed only in the vertical position.

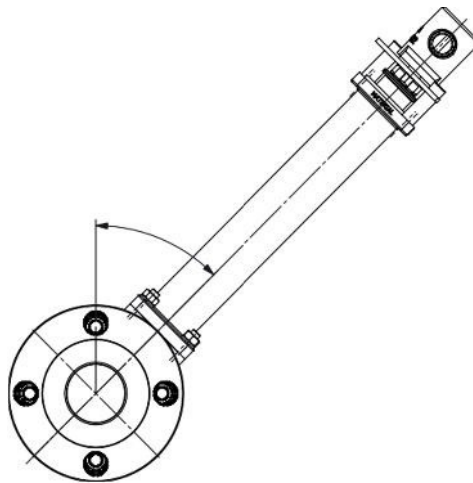

Figure 2. Valve tilting limitations



2.1.3. Support the pipeline properly and eliminate strain of the valve due to hydraulic forces and/or pipeline weight.

2.2. In-line welding of valve with extended pups

- 2.2.1. Keep the valve in 'full open' position.
- 2.2.2. Clean both mating parts before assembly.
- 2.2.3. Welding of valves shall be performed by a qualified welder according to the ASME Boiler Construction Code Section IX.
- 2.2.4. Align the valve to the pipeline, ensuring proper fit to minimize pipe load and maintain the 2 to 3 mm gap co-axially.
- 2.2.5. Use an internal welding backing ring where practical.
- 2.2.6. While welding, do not allow the temperature of valve body seat area to exceed 120°C (248°F) to prevent seat or seal damage. Use a temperature stick and a wet cloth wrapped around the center section to prevent overheating.
- 2.2.7. Do not allow rapid application of excess welding material.
- 2.2.8. Complete the welding operation and clean the pipeline and valve parts by flushing or pigging to remove all impurities left during the installation and welding process.
- 2.2.9. Do not to rotate the valve to the closed position before flushing the pipeline.

3. Operation

- 3.1. Icing of internal parts will damage the valve functionality, flush the valve and pipeline with Nitrogen or Helium (service dependent), and prevent air, moist, or any elements that may freeze during operation, from the cryogenic valve flow bore and pipeline.
- 3.2. To operate the Microfinish cryogenic ball valve turn the stem 90° clockwise to close and 90° counter clockwise to open.
- 3.3. Manually operated valves, the position of the lever aligned with the valve/pipeline axis indicates valve open position; position of the lever perpendicular to the valve/pipeline axis indicates valve close position for lever operated valves. The open close indicator is provided for gear operated valves.
- 3.4. The valve is intended for on-off service only; it should not be used for throttling services.
- 3.5. Valve should be "fully opened" or "fully closed" to prevent damage to the seat and ball.
- 3.6. Do not leave the valve in the partial open position.
- 3.7. Avoid side load on the valve stem.

4. Maintenance

- 4.1. Flush the valve and pipeline with nitrogen, whilst preventing the introduction of air, moisture or water into the cryogenic valves and pipelines, as this will freeze the valve and render in inoperable.
- 4.2. Regular maintenance or lubrication is not required for cryogenic ball valve.
- 4.3. If the body seal leak develops tighten the valve bolting to the torque figure in Table 2; if the body seal leak continues, replace the body seal.
- 4.4. If stem leak develops, tighten the stem nut to the torque figure in table 1; If the stem leak continues, replace the stem seal.
- 4.5. **Stem seal replacement:** depressurize the valve prior to replacing the stem seal. Remove all accessories including actuator and allow access to the stem seal. After loosening and removing the stem nut, Belleville springs and gland ring, the stem seal can be removed by means of hook tool; care must be taken not to score the stem polished surface, nor the valve body.
- 4.6. **Stem seal adjustment:**
 - a. Microfinish valves allows an externally adjustable stem seal in the event of stem leak.
 - b. Operate the valve once.
 - c. Loosen the stem nut for two turns.
 - d. Operate the valve three full cycles.
 - e. Tighten the stem nut as per **Table-1** column "**X**".
 - f. Loosen the stem nut.
 - g. Operate the valve three full cycles.
 - h. Retighten the stem nut as per **Table-1** column "**Y**".
 - i. Operate the valve three full cycles.
 - j. Record the torque.
 - k. In case the first attempt didn't stop the leak, repeat steps "d" to "j". If the leak continues replace the stem seal.

Table 1. Stem nut tightening torque (Nm)

Valve size	Series	Stem nut size	GRAPHITE		PTFE	
			X	Y	X	Y
DN15	C84F2, C85F2, C87F2	M10x1.5	10	5	9	5
DN20	C84R2, C85R2, C87R2	M10x1.5	10	5	9	5
DN20	C84F2, C85F2, C87F2	M12x1.75	15	7	13	5
DN25	C84R2, C84F2, C85R2, C85F2, C87R2, C87F2	M12x1.75	15	7	13	5
DN32	C84R2, C85R2, C87R2	M12x1.75	15	7	13	5
DN32	C84F2, C85F2, C87F2	M18x2	19	11	17	11
DN40	C84R2, C84F2, C85R2, C85F2, C87R2, C87F2	M18x2	19	11	17	11
DN50	C84R2, C85R2, C87R2	M18x2	19	11	17	11
DN50	C84F2, C85F2, C87F2	M20x2	22	19	20	15
DN65	C84F2, C85F2, C87F2	M27x2	29	19	27	18
DN80	C84R2, C84F2, C85R2, C85F2, C87R2	M27x2	29	19	27	18
DN80	C87F2	M39x2	34	22	32	20
DN100	C84R2, C84F2, C85R2, C85F2, C87R2	M39x2	34	22	32	20
DN100	C87F2	M45x2	50	32	37	39
DN150	C84R2, C84F2, C85R2, C85F2	M45x2	50	32	37	39

The stem nut is secured from opening by a nut lock clip. Push the clip tabs away from the stem nut with a flathead screwdriver; allow the stem nut a free rotation and reset the stem seal with the torque figures shown in table. After tightening the stem seal secure the nut lock clip by pushing the tabs toward the stem nut flats.

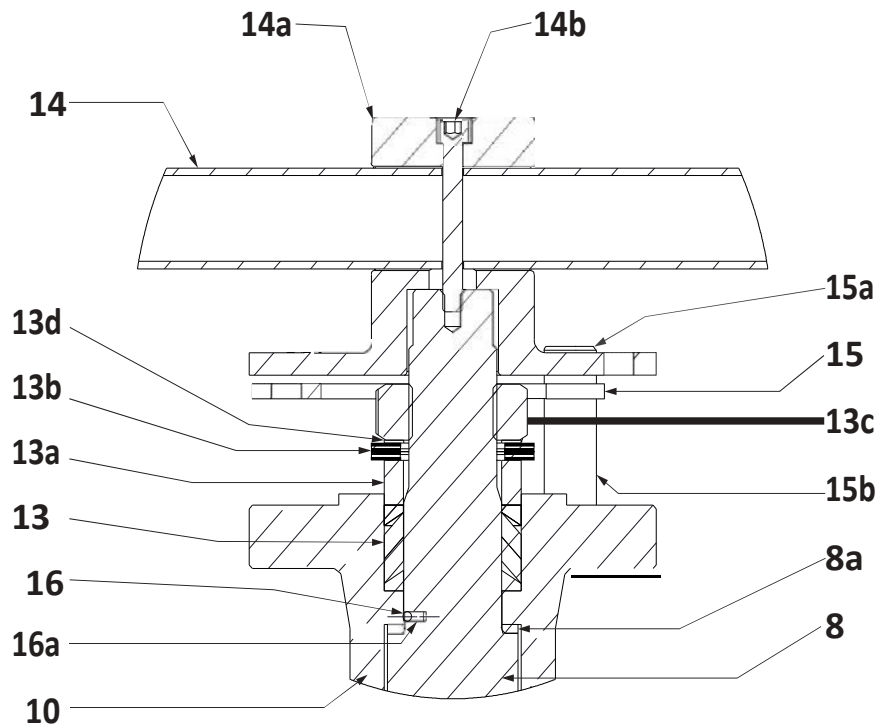

Figure 3. Stem seal arrangement

Item no.	Part description
8	Stem
8a	Stem thrust washer
10	Bonnet
13	Stem seal
13a	Gland
13b	Disc spring
13c	Stem nut
13d	Nut lock clip
14	Handle
14a	Handle adapter
14b	Handle adapter bolt
15	Locking disc
15a	Locking disc bolt
15b	Locking disc bush
16	Antistatic ball
16a	Antistatic spring



5. Disassembly

For your safety and protection, it is important that the following precautions will be taken prior to removing the valve from service, or before any disassembly of the valve.

5.1. Disassembly from pipe line

- 5.1.1. Wear an eye shield, protective clothing, gloves and footwear.
- 5.1.2. When necessary keep water available nearby and/or fire extinguisher.
- 5.1.3. De-pressurize the line and drain the valve.
- 5.1.4. Keep hands out of valve interior.
- 5.1.5. Disconnect all auxiliary piping, and pneumatic, or electric connection.
- 5.1.6. Keep the valve in the fully open position.
- 5.1.7. Remove the valve and place it on a clean surface.

5.2. Disassembly of the cryogenic floating ball valves

- 5.2.1. Flush the valve and remove any residuals from within.
- 5.2.2. Support the valve on a clean platform.
- 5.2.3. Remove all accessories if fitted and also adapter, lever or gear operator.
- 5.2.4. Unscrew the cryogenic bonnet from the body, and discard the body-bonnet seal.
- 5.2.5. Unscrew the body-end connection studs, separate the body, and end piece.
- 5.2.6. Remove the seats, ball, and body seals, and place them on a clean surface.
- 5.2.7. Discard the used body seals.
- 5.2.8. Remove the stem nut, disc springs, locking plate, and gland.
- 5.2.9. Pull down the stem outside of the bonnet; verify that the stem thrust washer is also removed.
- 5.2.10. Remove the stem seal from the bonnet top, without scoring the metallic sealing surfaces surrounding it.
- 5.2.11. Keep all disassembled metallic parts on a clean surface and discard the soft part.

6. Assembly

CAUTION !

Follow the safety rules and regulations to avoid personal injury or equipment damage

- 6.1. Use only Microfinish original spare parts.
- 6.2. Assembly of Oxygen service valve shall be held in an oil free zone.
- 6.3. Wear clean working clothes and latex gloves throughout the complete process.
- 6.4. Cover the working table with clean plastic sheet.
- 6.5. Before assembling the valve, examine all parts and replace any worn or damaged item.
- 6.6. Clean all parts carefully with Iso-Propyl Alcohol (IPA) and place them on the cleaned working area.
- 6.7. Lubrication is not required for cryogenic ball valve internals.
- 6.8. Smear small amount of BAM approved grease on body fasteners only.
- 6.9. For valve assembly, follow the disassembly steps (paragraph 5) in a reverse order.
- 6.10. Tighten the body bolts to the torque figures shown in Table 2 according to tightening pattern illustrated in figure 4.
- 6.11. Keep the valve in the open position for flushing purpose.

Table 2. Body bolts tightening torque

Valve size	Series	Thread size x pitch	Tightening torque for lubricated fastener	
			Nm	lbf.in
DN15	C84F2, C85F2, C87F2	M8x1.25	11-14	97-124
DN20	C84R2, C85R2, C87R2	M8x1.25	11-14	97-124
	C84F2, C85F2, C87F2	M10x1.5	22-24	195-212
DN25	C84R2, C84F2, C85R2, C85F2, C87R2, C87F2	M10x1.5	22-24	195-212
DN32	C84R2, C85R2, C87R2	M10x1.5	22-24	195-212
	C84F2, C85F2, C87F2	M12x1.75	37-39	327-345
DN40	C84R2, C85R2, C87R2	M12x1.75	37-39	327-345
	C84F2, C85F2, C87F2	M14x2	55-57	487-504
DN50	C84R2, C85R2, C8RF2	M14x2	55-57	487-504
	C84F2, C85F2, C8RF2	M14x2	55-57	487-504
DN65	C84F2, C84R2	M12x1.75	37-39	327-345
	C85F2, C85R2	M14x2	55-57	487-504
	C87F2, C87R2	M16x2	83-87	735-770
DN80	C84R2	M12x1.75	37-39	327-345
	C84F2, C85R2	M14x2	55-57	487-504
	C85F2, C87R2, C87F2	M16x2	83-87	735-770
DN100	C84F2, C84R2	M14x2	55-57	487-504
	C85F2, C85R2, C87F2, C87R2	M16x2	83-87	735-770
DN150	C84R2	M14x2	55-57	487-504
	C84F2, C85R2	M16x2	83-87	735-770
	C85F2	M20x2.5	165-170	1460-1505

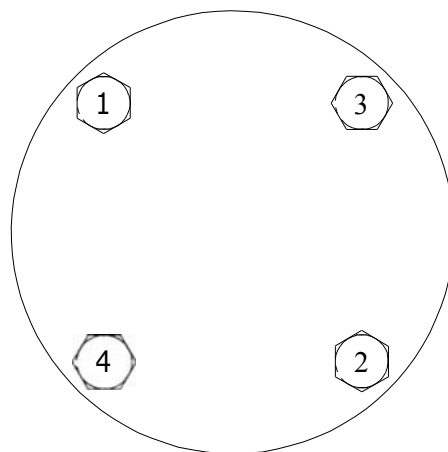





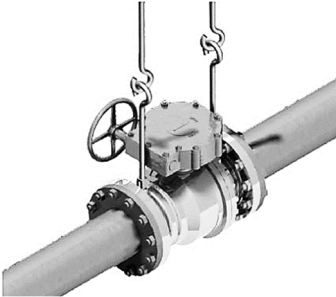
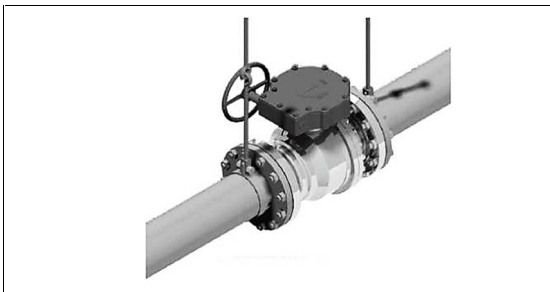

Figure 4. Fastener tightening sequence

7. Lifting instructions

Lifting plates are provided for valve weighing 25 KG and above unless otherwise specified by the customer. Lifting plates are verified for suitability through design calculations with respect to valve weight along with the operator assembly and accessories. Lifting sketches and handling instructions for safe lifting operation for valves weighing more than 25 KG is as shown in the below figures. The safe working Limit (SWL) of each lifting point is marked on the lifting plate. Lifting plates are to be affixed to the valve flange for valves weighing 25 KG and above by balancing with respect to center of gravity of the valve along with the valve accessories if any.

	
<p>Way of Hosting the Ball Valve</p>	<p>Avoid this way of Hosting the Ball Valve</p>
	
<p>Way of Hosting the Ball Valve</p>	<p>Avoid this way of Hosting the Ball Valve</p>
	
<p>Valve ready for Disassembling supported on Platform</p>	<p>Way of supporting the Ball Valve</p>



Way of supporting the Ball Valve



Way of supporting the Ball Valve

➤ Method of Lifting for Actuated Ball Valves

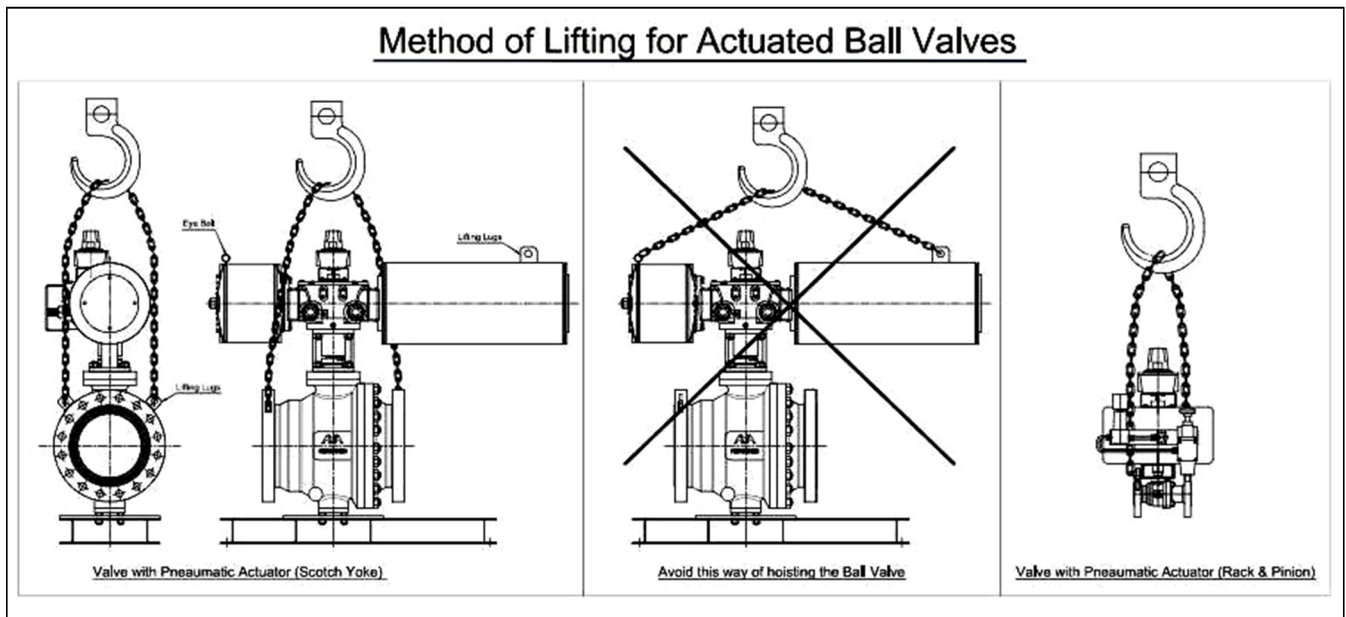

➤ Instruction for lifting the valve assembly

Valve shall be lifted using the lifting lugs provided on the valve. Eye bolts provided on the actuator shall not be used for lifting the entire valve – actuator assembly. Eye bolting actuator shall be used only for lifting the actuator during maintenance if any.

Along with the lifting lugs provided on the valve, eye bolts provided on the actuator may also be used for balancing if needed while lifting.

While lifting the valve assembly care should be taken to see that the tubing and accessories mounted on the valve and actuator are not damaged.



8. Troubleshooting

Sl.No.	Malfunction	Possible cause	Remedial action
1	In line leak	<ol style="list-style-type: none"> 1. Seat damage due to the presence of foreign particles. 2. Seat damage during welding. 3. Seat damage due to high temperature service. 4. Improper adjustment of automated valve. 	<p>Dismantle, clean & replace with new seats.</p> <p>Follow the welding instructions published in this IOM.</p> <p>Check the seat material compatibility with the service.</p> <p>Ensure proper adjustment of the actuator.</p>
2	Stem seal leak	<ol style="list-style-type: none"> 1. Loosen stem nut or nut lock clip. 2. Damage/wear of stem seal/stem thrust washer. 3. Misalignment of actuator, bracket & stem. 	<p>Tighten the stem nut / fix the nut lock clip tabs with the stem nut flats.</p> <p>Replace the stem seal/stem washer.</p> <p>Ensure proper alignment between all parts.</p>
3	Body seal leak	<ol style="list-style-type: none"> 1. Improper tightening of Body bolting. 2. Damage during welding. 3. Misalignment of pipeline mating flanges. 	<p>Ensure proper tightening of body bolts.</p> <p>Follow the welding instructions published in this IOM.</p> <p>Ensure correct alignment of flanges.</p>
4	High torque operation	<ol style="list-style-type: none"> 1. High temperature fluid handled. 2. Highly viscous fluid handled. 3. Insufficient air supply pressure in case of pneumatic operated valves. 4. Reducing of lever length by user due to lack of space. 5. Pipeline flange pressure in case of single piece valves. 	<p>Check for compatibility of material and design.</p> <p>Check for compatibility of material and design.</p> <p>Ensure sufficient air flow and pressure.</p> <p>Use lever of correct length.</p> <p>Face the seat or seat seal to relieve extra pressure.</p>
5	Jerky operation	<ol style="list-style-type: none"> 1. Presence of foreign particles at seat contact area. 2. Peeling of plating of Ball in case of metal seated valves. 3. Insufficient air supply pressure in case of pneumatic operated valves. 	<p>Dismantle, Clean & Reassemble.</p> <p>Check for service condition/replace.</p> <p>Ensure sufficient air flow and pressure.</p>



9. SIL

Under normal operating conditions, the Microfinish valve should be inspected for proper functioning and signs of deterioration once in every six months. Under severe operating conditions, inspection shall be taken place more frequently.

Severe operating conditions can be defined as:

- Operating temperature less than -49° C.
- Operating temperature higher than +230° C.
- Flow velocity higher than 5 m/sec for liquids, and 200 m/sec for gases.
- Acidic media PH < 5 or Alkaline media PH > 9.

Microfinish recommends a partial stroke test once in 12 months to confirm proper functioning of the system.

It is essential to record the date, time, name and signature of the responsible engineer, air pressure on site, time to close the valve, time to open the valve.

Microfinish recommends inspecting the valve wall thickness every time the valve is maintained. When the valve body thickness is eroded, corroded, or mechanically removed by 1 mm (combined corrosion and erosion allowance for the valve wall thickness) the valve should no longer be used.

Any failure affecting the product's functional safety shall be reported to Microfinish Valves Pvt Ltd.

Valve exploded view: Cryogenic floating ball valve

Full or reduced bore, two piece, flanged or welded end connection

Materials of construction

Item No.	Part description	Material specification
1	Body	ASTM A351 Gr CF8M, CF8
2	End	ASTM A351 Gr CF8M, CF8
3	Ball	ASTM A351 Gr CF8M, CF8
4	Stem	ASTM A479 316, Nitronic XM-19
*4a	Stem thrust washer	CFT, PCTFE
*4b	Stem bearing	PTFE
*5	Seat	PCTFE, CFT
*6	Body seal	Graphite, PTFE
7	Body stud	ASTM A320 Gr B8M Class 2, Gr B8 Class 2
7a	Body nut	ASTM A320 Gr 8M, Gr 8
7b	Body spring washer	SS304
*8	Stem seal	Graphite, PTFE
8a	Gland	SS304 / CF8
8b	Disc spring	SS304
8c	Stem nut	SS304
8d	Nut lock clip	SS304
10	Cryogenic bonnet	ASTM A351 Gr CF8M, CF8
11	Bonnet bolt	ASTM A320 Gr B8M Class 2
11a	Bonnet spring washer	SS304
11b	Bonnet nut	ASTM A320 Gr 8M, Gr 8
*12	Bonnet seal	Graphite, PTFE
14	Arrow flow plate (not shown)	SS304
16	Antistatic plunger (not shown)	SS316
16a	Antistatic spring (not shown)	SS316
17	Valve tag (not shown)	SS304
18	Lock disc	SS304
18a	Lock disc bolt	SS304
18b	lock disc bushing	SS304
19	Handle	CS Zinc plated
19a	Handle adaptor	CS epoxy painted
19b	Handle sleeve	PVC
19c	Adaptor bolt	CS Zinc plated
19d	Handle bolt	CS Zinc plated
19e	Handle bolt washer	CS Zinc plated

* Repair kit item

Valve exploded view

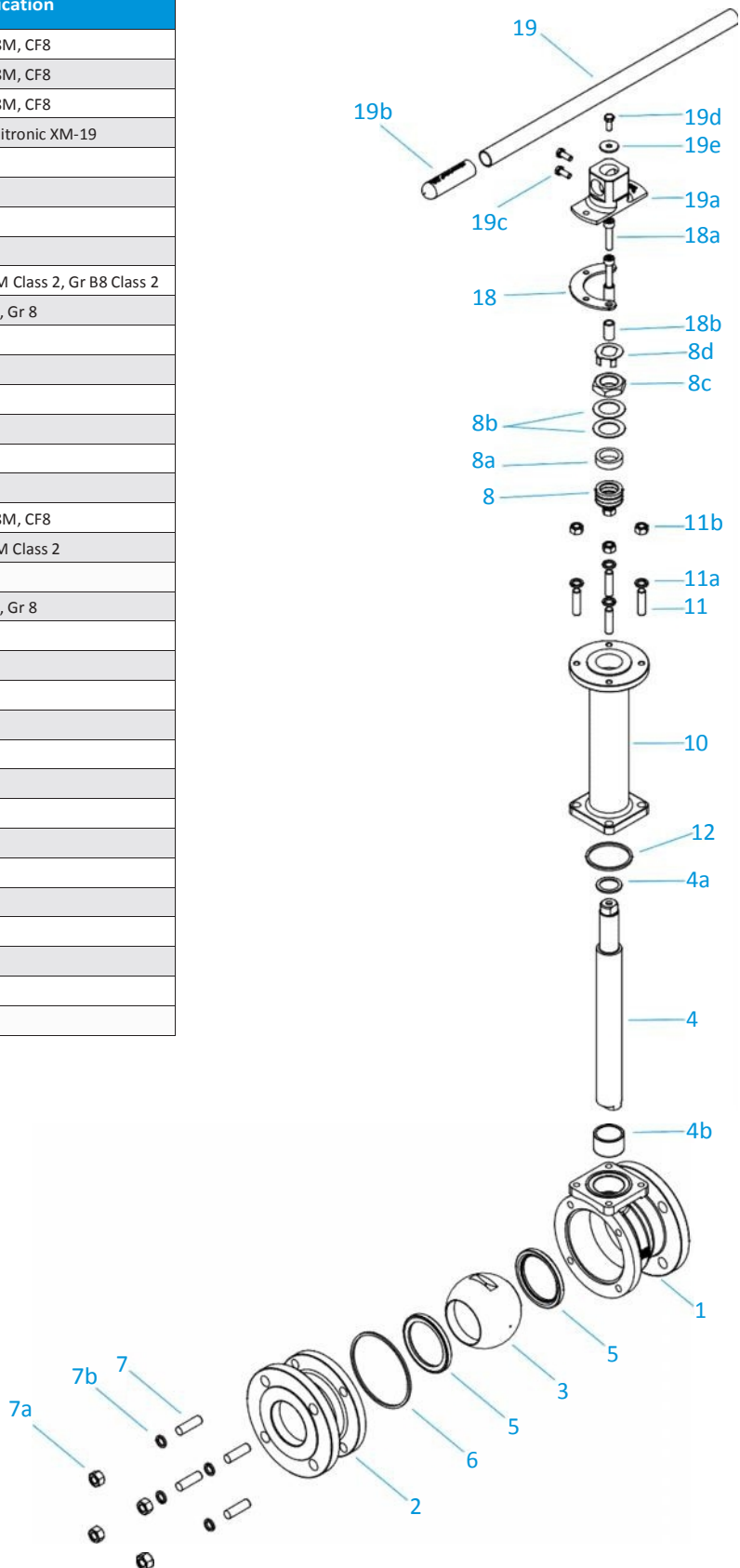

Figure 5. Full bore Cryogenic floating ball valve, three piece design



MICROFINISH VALVES

Quality you can trust.

MICROFINISH VALVES PVT. LTD. 

Block no.23B, Plot no.1 to 6, Hubballi-Dharwad Bypass Road, Itigatti Village,
Dharwad-580 114, Karnataka state, India. Phone: +91 836 2310015 / 16 / 19
Email: sales@microfinishgroup.com Website: www.microfinishgroup.com

THE AMERICAS

MICROFINISH VALVES, INC. 

7505 Bluff Point Drive, Suite 100 Houston, Texas 77086, United States.
Phone: +1 281-885-4250 / +1 281-885-4259 Fax: +1 281-866-0996
Email: usasales@microfinishgroup.com Website: www.microfinishvalvesinc.com